

8 7 6 5 4 3 2 1

REVISIONS				
ZONE	REV.	DESCRIPTION	DATE	APPROVED
	000	INITIAL RELEASE	10/13/2015	
	001	WIDER LAYOUT	03/21/2016	
	002	IMPROVED COMPONENT FITMENT	09/27/2016	

2X ϕ .14in [3.500mm] ∇ .20in [5mm]
 \sphericalangle ϕ .26in [6.500mm] X 100°

2X ϕ .11in [2.705mm] THRU
 6-32 UNC THRU 通牙
 THREADED TAP EXTRUDE

拉伸攻牙

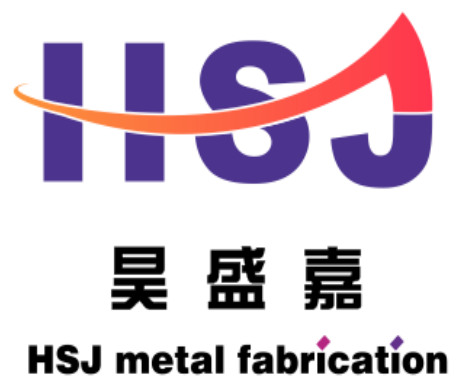
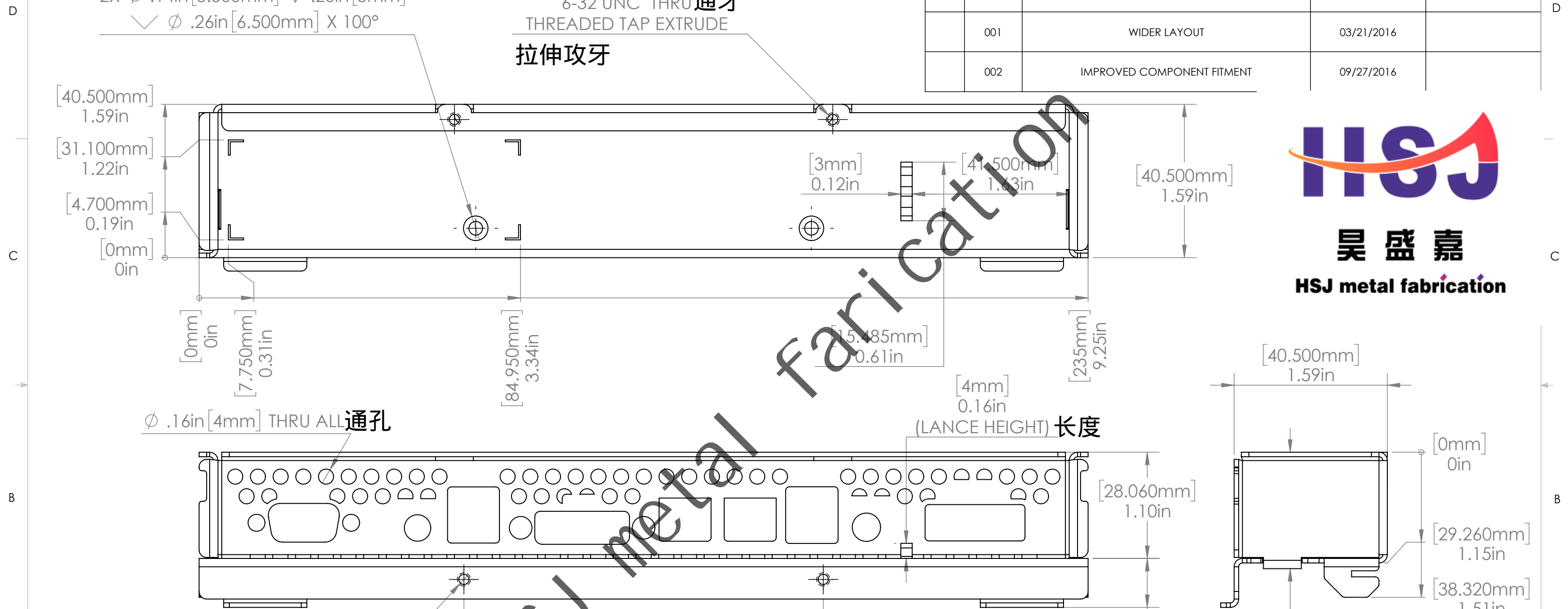

ϕ .16in [4mm] THRU ALL 通孔

4mm 0.16in (LANCER HEIGHT) 长度

2X ϕ .11in [2.705mm] THRU ALL
 6-32 UNC THRU ALL
 THREADED TAP EXTRUDE

YXPO161063(Candice)2#
 数量 : 500件
 材料 : 1.2mm镀锌钢
 表处 : 无

UNLESS OTHERWISE SPECIFIED:		NAME	DATE	TITLE:	
DIMENSIONS ARE IN MILLIMETERS		DRAWN	REG		10/13/15
TOLERANCES:		CHECKED			
FRACTIONAL \pm		ENG APPR.			
ANGULAR: MACH \pm .10 BEND \pm .10		MFG APPR.			
TWO PLACE DECIMAL \pm 0.10		Q.A.			
THREE PLACE DECIMAL \pm 0.105		COMMENTS:			
INTERPRET GEOMETRIC TOLERANCING PER:				SIZE DWG. NO. DOC REV	
MATERIAL:				B OM4-P05-R2 003	
1.2mm E-GAL STEEL				SCALE: 1:1 WEIGHT: SHEET 1 OF 1	
FINISH					
NEXT ASSY	USED ON				
APPLICATION		DO NOT SCALE DRAWING			

8 7 6 5 4 3 2 1

YXPO161063(Candice)4#

材料：3mm冷轧钢

表处：镀蓝锌

数量：500件

REVISIONS

ZONE	REV.	DESCRIPTION	DATE
	000	INITIAL RELEASE	10/13/2015
	001	REVISED WITH BAIL MOUNT	03/21/2016

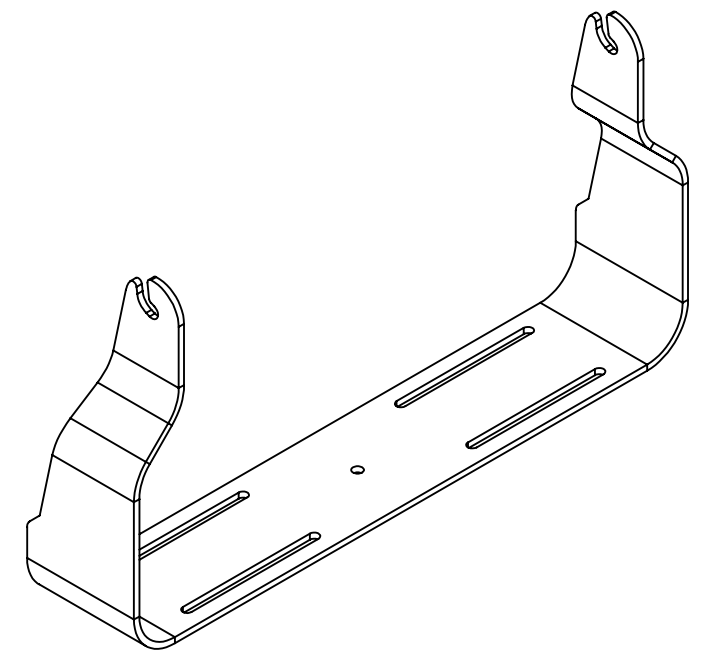
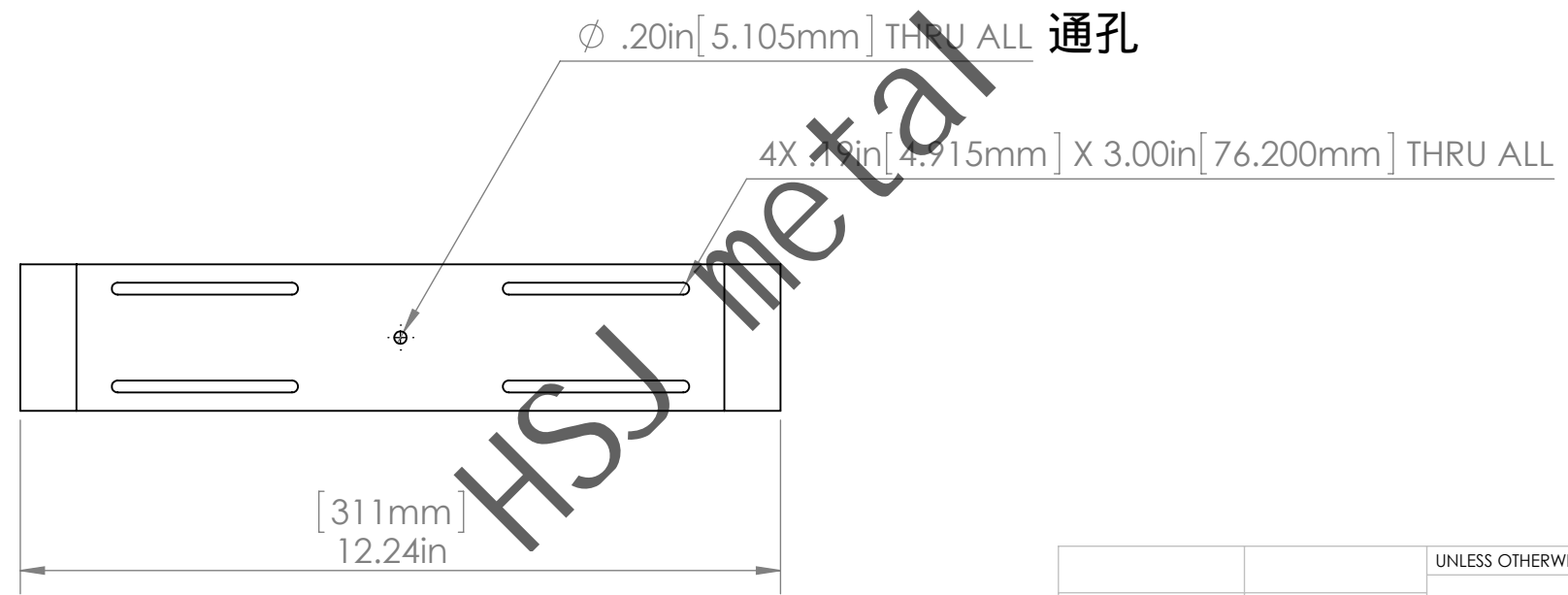
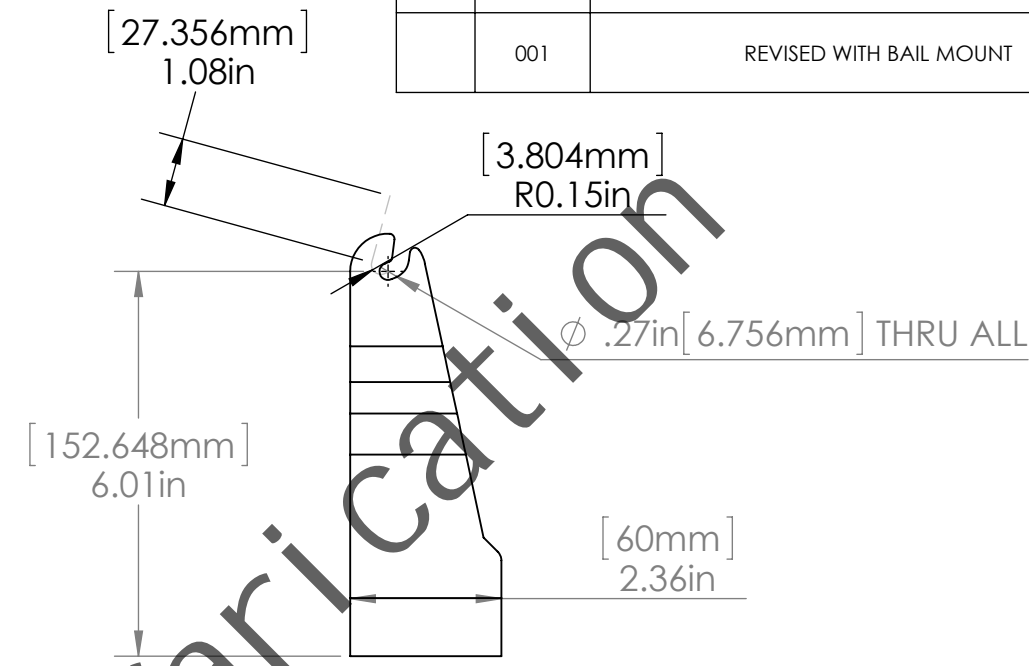
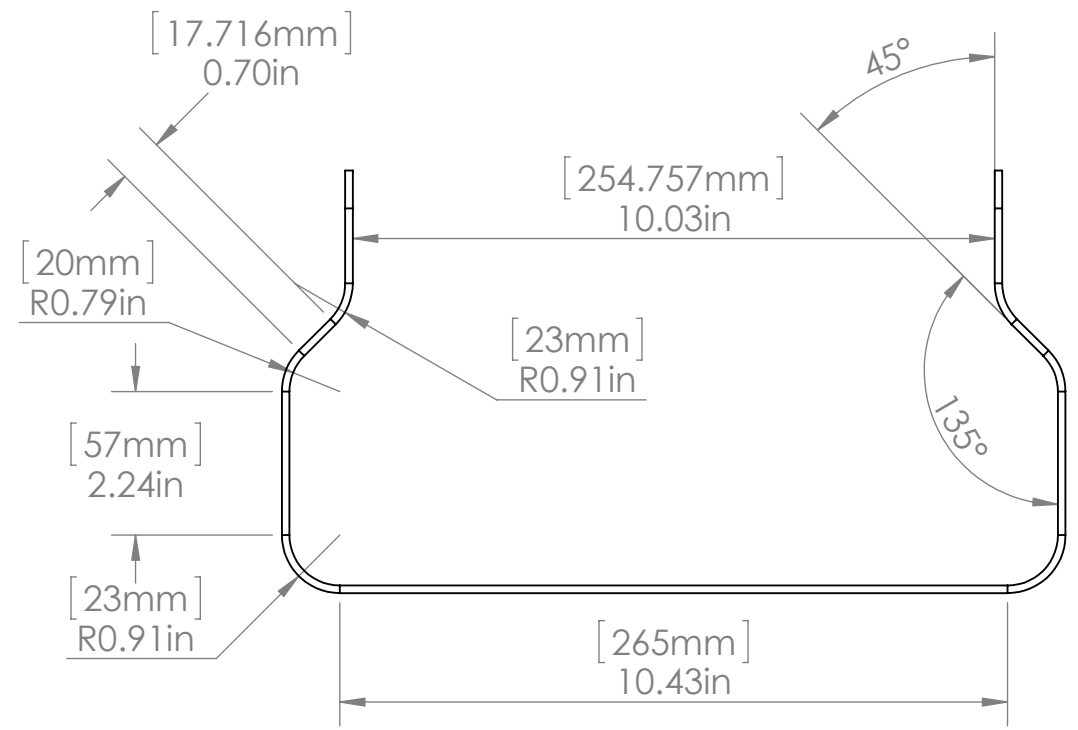

		UNLESS OTHERWISE SPECIFIED:		NAME
		DIMENSIONS ARE IN MILLIMETERS	DRAWN	REG 1C
		TOLERANCES:	CHECKED	
		FRACTIONAL ±	ENG APPR.	
		ANGULAR: MACH ± .10 BEND ± .10	MFG APPR.	
		TWO PLACE DECIMAL ± 0.10	Q.A.	
		THREE PLACE DECIMAL ± 0.105	COMMENTS:	
		INTERPRET GEOMETRIC TOLERANCING PER:		
		MATERIAL:		
		3mm COLD ROLLED STEEL		
NEXT ASSY	USED ON	FINISH:		
		CLEAR ZINC PLATING		
APPLICATION		DO NOT SCALE DRAWING		

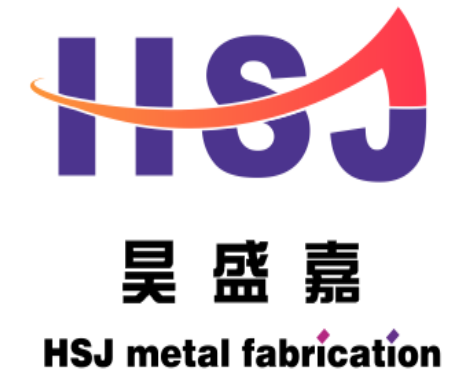

REV 1
F 1

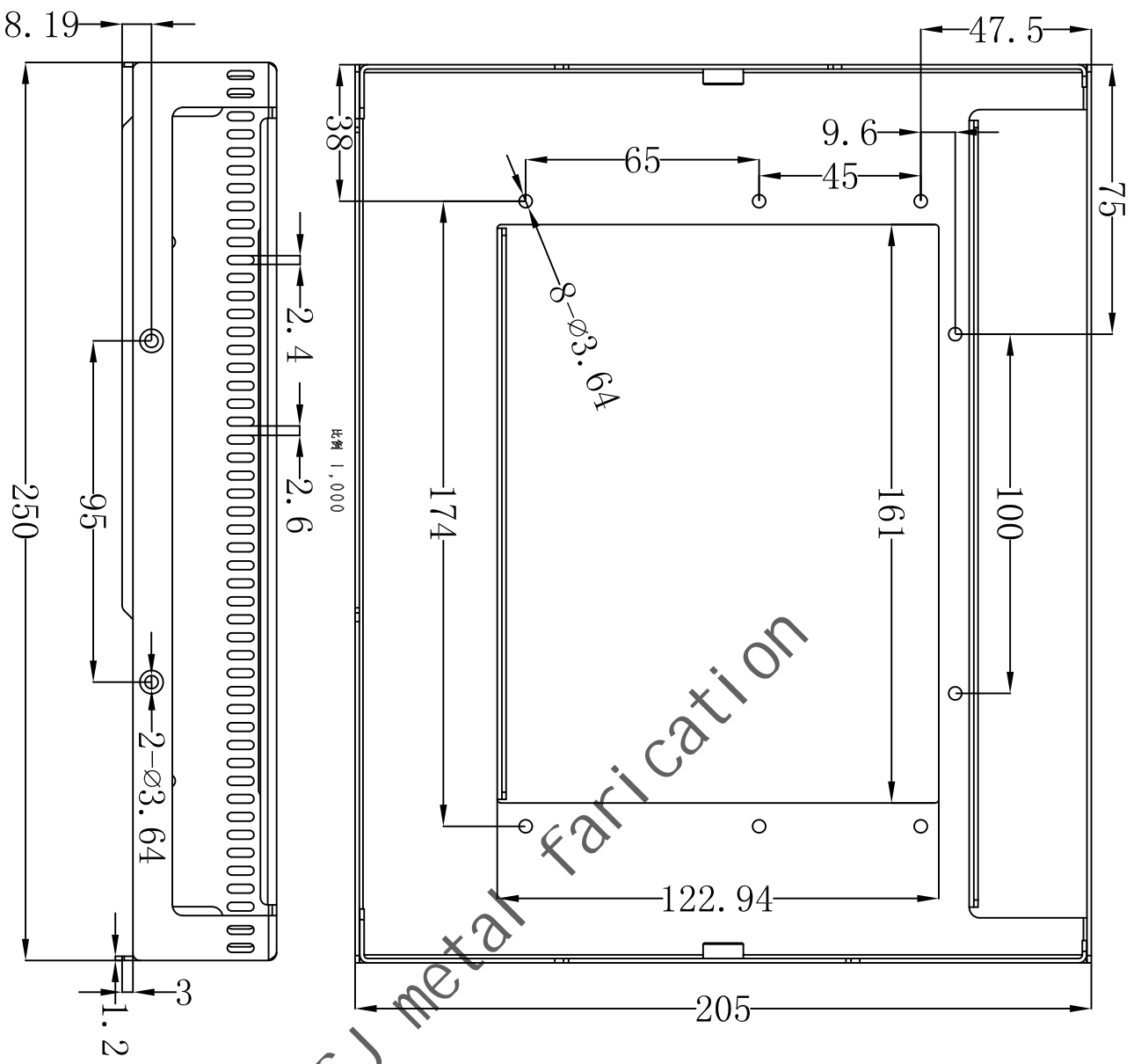

HSJ metal fabrication

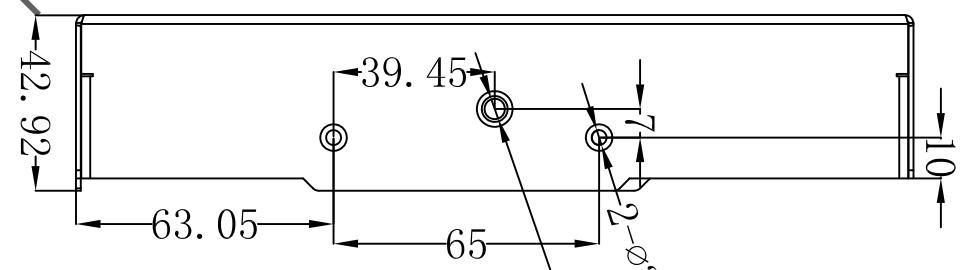

铆钉 S-0420-OZ1
 $\phi 4.98$

- 1: 每件配8个6-32牙-6mm长度镀锌螺丝;
- 2: 上次的订单客户反馈了产品4个角锋利问题, 这次一定处理圆顺。

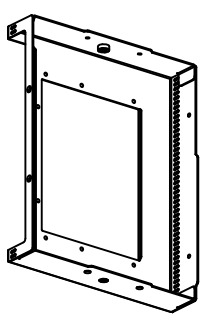

Free	0-6	±0.05
6-30	±0.1	
30-120	±0.15	
120-400	±0.2	
Tolerance		容许公差
自由公差		± 0.1°
尺寸范围		
Size range		Allowance tolerance



昊盛嘉

HSJ metal fabrication